

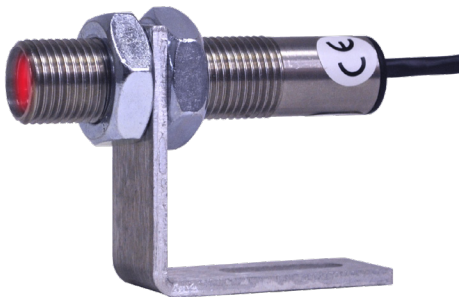

Instruction Manual

**ROS / ROSM
Remote Optical Sensor /
Modulated Remote Optical Sensor**



15 Columbia Drive

Amherst, NH 03031 USA

Phone: (603) 883-3390 • Fax: (603) 886-3300

E-mail: support@monarchinstrument.com

Website: www.monarchinstrument.com



SAFEGUARDS AND PRECAUTIONS



Read and follow all instructions in this manual carefully, and retain this manual for future reference.

Do not use this instrument in any manner inconsistent with these operating instructions or under any conditions that exceed the environmental specifications stated.

This instrument is not user serviceable. For technical assistance, contact the sales organization from which you purchased the product.



In order to comply with EU Directive 2012/19/EU on Waste Electrical and Electronic Equipment (WEEE): This product may contain material which could be hazardous to human health and the environment. DO NOT DISPOSE of this product as unsorted municipal waste. This product needs to be RECYCLED in accordance with local regulations; contact your local authorities for more information. This product may be returnable to your distributor for recycling; contact the distributor for details.

Monarch Instrument's Limited Warranty applies.
See www.monarchinstrument.com for details.

Warranty Registration and Extended Warranty Coverage information is available online at www.monarchinstrument.com.

TABLE OF CONTENTS:

1.0 DESCRIPTION	1
1.1. ROS Models	1
1.2 ROSM Modulated Models	1
2.0 MODELS WITH STEREO PLUG	2
2.1 Connection Detail for Metal Plug	2
2.2 Connection Detail for Molded Plug	3
3.0 MODELS WITH TINNED WIRES.....	3
3.1 Connection Detail for ROS-W/ROSM-5W.....	3
4.0 OPERATION INSTRUCTIONS.....	3
5.0 SPECIFICATIONS	5
5.1 Dimensions of Mounting Bracket (inches)	6
5.2 Compliance.....	7
6.0 ACCESSORIES	7

1.0 DESCRIPTION

The **ROS** and **ROSM** are versatile Remote Optical Sensors that have a visible red LED light source and green LED on-target indicator. The sensors are housed in a threaded 303 stainless steel tube and are built with various length cables terminated with either tinned wires or 1/8" [3.5 mm] male stereo plug. All models (except the ROSM-5W) are supplied with a 90° mounting bracket and jam nuts.

1.1. ROS Models

The standard **ROS Remote Optical Sensor** can accurately measure speeds from 1-250,000 RPM from a distance of up to 36 inches with a maximum offset angle of 45 degrees from the rotating object. Standard **ROS** models consist of the following:

Model	Cable Length	Cable Termination
ROS-P	8 feet	1/8 in. [3.5 mm] male stereo plug
ROS-W	8 feet	Tinned wires
ROS-P-25	25 feet	1/8 in. [3.5 mm] male stereo plug
ROS-W-25	25 feet	Tinned wires

1.2 ROSM Modulated Models

The **ROSM Modulated Remote Optical Sensor** is designed specifically for use in high-ambient light applications where other optical sensors frequently suffer from light interference. It can measure speeds from 1-20,000 RPM from a distance of 1 inch up to 24 inches with a maximum offset angle of 45 degrees from the rotating object.

How it works: Instead of being on continuously like our other optical sensors, the LED light source in the ROSM is modulated on and off at a high frequency. That high frequency light signal is reflected back at the sensor for processing while all other sources of light are filtered out and/or ignored.

The **ROSM** is available in the following configurations:

Model	Cable Length	Cable Termination
ROSM-5P	8 feet	1/8 in. [3.5 mm] male stereo plug
ROSM-5W	22 feet	Tinned wires

2.0 MODELS WITH STEREO PLUG

All **ROS** and **ROSM** models with the 1/8 inch [3.5 mm] male stereo plug are designed to plug into most Monarch tachometers and stroboscopes.

The **ROS-P** and **ROS-P-25** models will work directly with all Monarch handheld tachometers and stroboscopes that accept pulse input through an input jack (e.g. PLT200, PLS Pocket LED Strobe, Nova-Strobe dax, Nova-Strobe dbx, Nova-Strobe DBL, Nova-Strobe pbx, Phaser Strobe PBL, Nova-Pro® 300, and Nova-Pro® 500).

The **ROSM-5P** will work directly with all Monarch Deluxe Stroboscopes (e.g. Nova-Strobe dax, Nova-Strobe dbx, Nova-Strobe DBL, Nova-Strobe pbx, Phaser Strobe PBL, Nova-Pro® 300, and Nova-Pro® 500).

A sensor power supply (SPSR-IM) with BNC output is available for those applications that require a separate power source for the sensor. An optional 25 ft. [7.6 m] extension cable (EC-25P) is available with a female socket for the plug on one end and a 3.5 mm [1/8 in.] male stereo plug on the other.

2.1 Connection Detail for Metal Plug

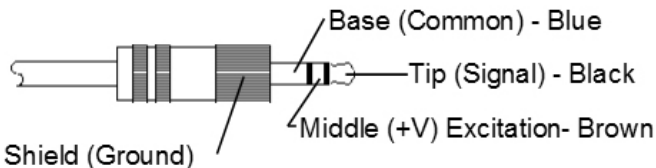

2.2 Connection Detail for Molded Plug

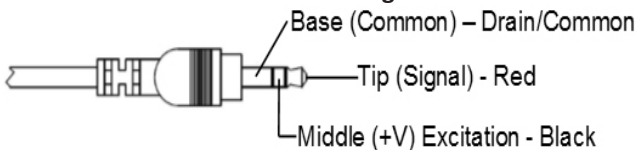

3.0 MODELS WITH TINNED WIRES

All **ROS** and **ROSM** models with tinned wires are designed to connect into any Monarch panel instrument that accepts pulse inputs (e.g. ACT Series, F2A1X and F2A3X Frequency to Analog Converters, DataChart™ 1250, DataChart™ 6000).

3.1 Connection Detail for ROS-W/ROSM-5W

Wire Color	Function	Connect To
Brown	Positive Power Excitation	+V
Blue	Common	Com
Black	Signal (+V to 0VDC Pulse)	Sig
Shield	Housing Ground	Gnd

4.0 OPERATION INSTRUCTIONS

The **ROS** is capable of detecting a reflected pulse from a target consisting of T-5 Reflective Tape at distances of up to 36 inches [1 m] from the rotating object and angles up to 45 degrees. The **ROSM** is capable of detecting a reflected pulse from a target consisting of T-5 Reflective Tape at distances of 1 to 24 inches from the rotating object and angles up to 45 degrees.

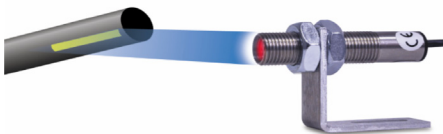

For most applications, a ½" [12 mm] square piece of Reflective Tape (T-5) should be applied to a clean area on the rotating object.

The **ROS** and **ROSM** should be mounted (using the supplied jam nuts and aluminum mounting bracket) and optically aligned to illuminate the on-target indicator once per revolution. The user must hold “steady” or mount the sensor to obtain an accurate measurement. The optical sensor must be placed at a slight angle (15 degrees recommended) from perpendicular, so that the sensor will receive only pulses from the reflective marker. The sensor must be at least 1 inch from the reflective target to avoid false triggering. The green LED On-Target Indicator will blink at the input frequency rate when the sensor is properly aimed.

NOTE: The green LED On-Target Indicator will blink on and off at slow speeds and remain on steady at high speeds.

5.0 SPECIFICATIONS

Specifications*	ROS	ROSM
Speed Range	1-250,000 RPM	1 - 20,000 RPM
Illumination	Visible red LED	
On-Target Indicator	Green LED on wire end cap	
Operating Range	Up to 36 in. [0.9 m] and 45° offset from target	1 in. [2.5 cm] up to 24 in. [0.6 m] and 45° offset from target
Power Requirement	3.0 - 15 V dc @ 40 mA	5.0 - 24 V dc @ 50 mA
Output Signal	Negative pulse input voltage (+V) to 0	Positive pulse input voltage 0 to +5 V
Operating Temp.	14 °F to 158 °F [-10 °C to 70 °C]	
Humidity	Maximum relative humidity 80% for temperature up to 88 °F (31 °C) decreasing linearly to 50% relative humidity at 104 °F (40 °C)	
Connection	1/8 in. [3.5 mm] male stereo plug (ROS-P, ROS-P-25 and ROSM-5P); Tinned wires (ROS-W, ROS-W-25 and ROSM-5W)	
Cable Length	ROS-P, ROS-W: 8 ft. [2.4 m] ROS-P-25: 25 ft. [7.6 m] ROS-W-25: 25 FT. [7.6 m]	ROSM-5P: 8 ft. [2.4 m] ROSM-5W: 22 ft. [6.7 m]
Material	303 stainless steel tube supplied with mounting bracket and two M16 jam nuts†	
Lens	Acrylic plastic	
Dimensions	Threaded tube: 2.90 in. x 0.625 in. diameter [M16 x 1.5 x 74 mm] long	

*Specifications are subject to change without notice.

†ROSM-5W doesn't come with mounting bracket and jam nuts

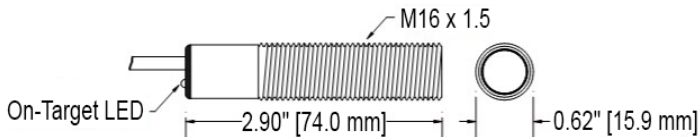

5.1 Dimensions of Mounting Bracket (inches)

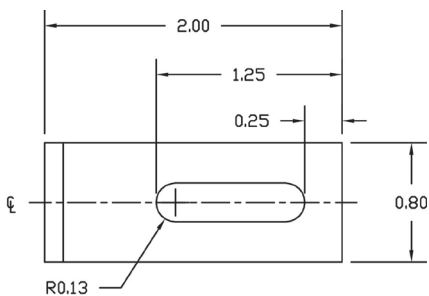
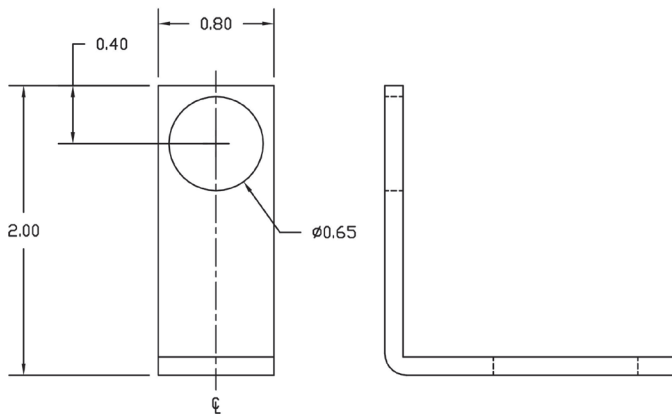

5.2 Compliance

- CE Compliant

NOTE: In order for the ROSM to be fully CE compliant, the supplied ferrite must be attached around the cable towards the ROSM end.

6.0 ACCESSORIES

[See the ROS Accessories webpage for details.](#)

SPSR Self-Powered Sensor - Interface Module
PN: 6150-021



EC-25P 25-Ft. Extension Cable
PN: 6180-028



Mounting Hardware
"L" bracket and mounting nuts
PN: 4180-287



T-5 Reflective Tape
5 ft. [1.5 m] roll, 0.5 inch wide
PN: 6180-070



This page intentionally left blank.

The Professional's Choice

Monarch Instrument is committed to excellence and quality in manufacturing, sales, and service.



Portable
Tachometers



Track-It™ Data Loggers



Panel Tachometers



Fixed Mounted
Strobes



Portable Strobes



Frequency
Converters



Speed Sensors



DataChart™ Paperless
Recorders



MONARCH
INSTRUMENT

15 Columbia Drive, Amherst NH 03031 USA

Tel.: (603) 883-3390 // Fax: (603) 886-3300

Email: support@monarchinstrument.com

Website: www.monarchinstrument.com