

Field Installation Instruction

3 Channel / 6 Channel Mechanical / Solid State Relay Option for the DIN Standard [144 mm x 144 mm] Data Recorder

WARNING: Due to hazardous voltages on the Rear Terminal Panel, use extreme caution when installing or servicing your instrument. Please read the entire contents of the Installation and Wiring Chapter before attempting to install or service your instrument.

WARNING: Before attempting to remove the unit from the panel, opening the front or working on the back of the instrument, ensure that the AC mains to the unit is **SWITCHED OFF** and **REMOVE THE POWER CORD** from the socket on the rear panel. Ensure that all live connections to the rear panel terminals are **ISOLATED** before removing the wiring.



Set Jumpers

The opto-isolated inputs require an external potential of 5 to 12 Volts DC @ 10mAmps by default. To activate the inputs via potential free contacts (contact closure), jumpers need to be set as described below:

1. Remove the circuit board from the rear panel (See Figure 1).

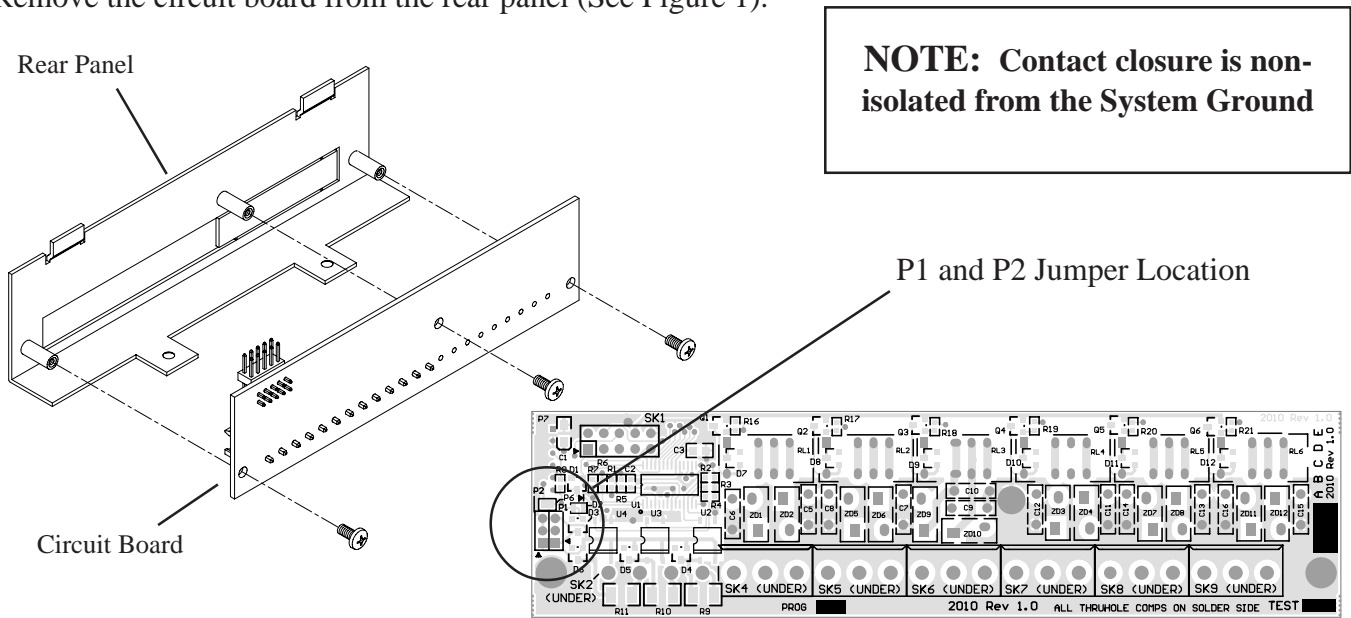

Figure 1 Jumper Location (Mechanical Relay shown - The jumpers for the Solid State Relay are in the same location.)

2. Set the jumpers according to Table 1:

	Mechanical Relay (2010 Rev 1.0 and higher)		Solid State Relay (2011 Rev 1.2 and higher)	
	P1	P2	P1	P2
Isolated Input External Drive (Default)	2 - 3	2 - 3	1 - 2	Open
Non-Isolated Contact Closure	1 - 2	1 - 2	2 - 3	Closed

Table 1 Jumper Positions

3. Screw the circuit board back onto the rear panel.

Install Relay Option

To install the 3 or 6 Channel Mechanical or Solid State Relay Option into the DIN Standard [144 mm x 144 mm] Data Recorder:

1. Unplug the recorder.
2. Plug the connector and metal tabs of the Relay option into the recorder case as shown in Figure 2.
3. Install two #4-40 x 1/4 flat head screws as shown below to secure the Relay option.
4. Plug the recorder in. The unit will automatically recognize the addition of the Relay option.

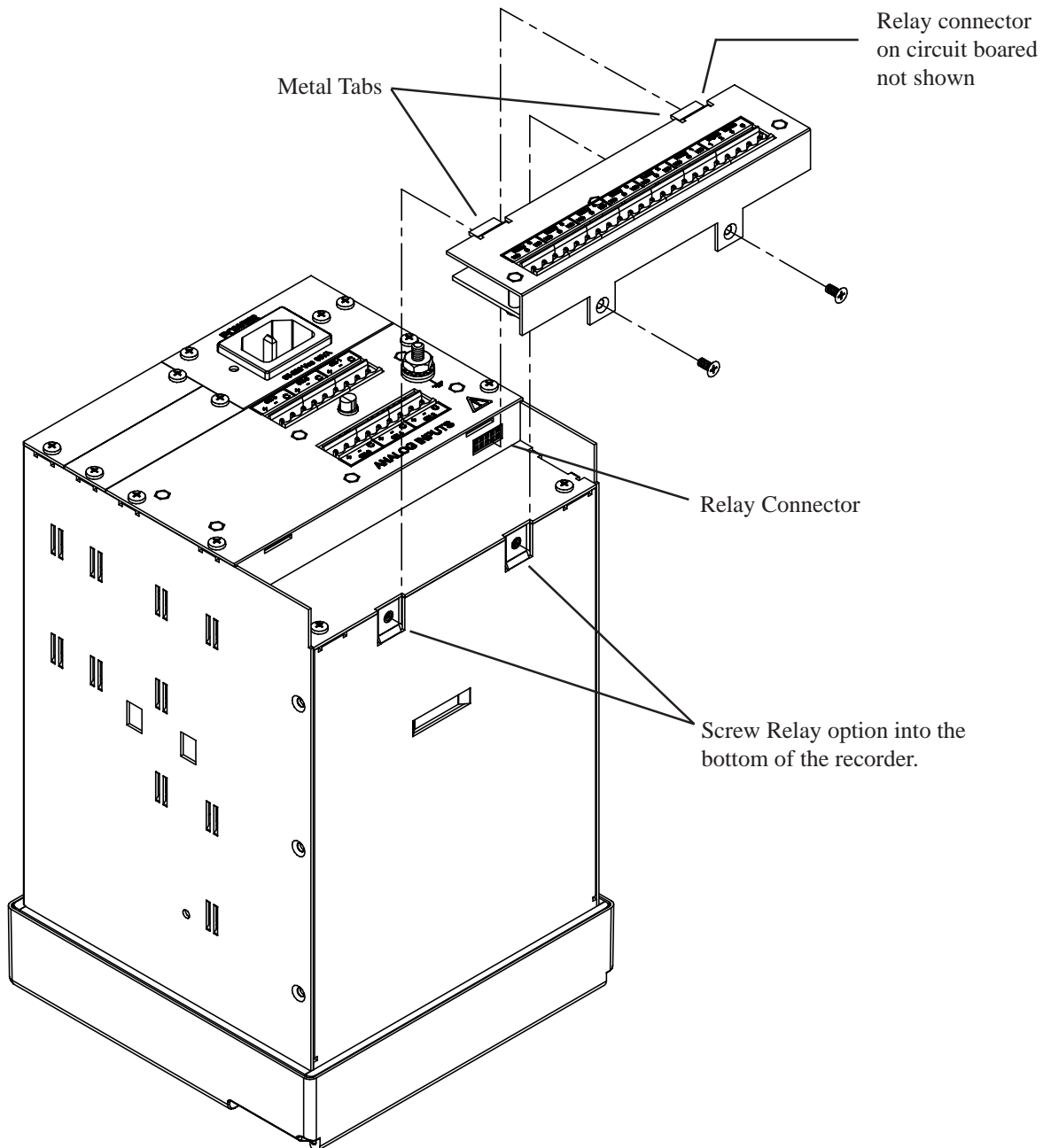

Figure 2 Relay Board Installation