



MONARCH INSTRUMENT

Instruction Manual



SPSR-115/230



SPSR-115/230
Self-Powered Sensor
TTL Pulse Output

15 Columbia Drive
Amherst, NH 03031 USA
Phone: (603) 883-3390
Fax: (603) 886-3300

E-mail: support@monarchinstrument.com
Website: www.monarchinstrument.com



Safeguards and Precautions



1. Read and follow all instructions in this manual carefully, and retain this manual for future reference.
2. Do not use this instrument in any manner inconsistent with these operating instructions or under any conditions that exceed the environmental specifications stated.
3. This instrument is not user serviceable. For technical assistance, contact the sales organization from which you purchased the product or Monarch Instrument directly.



In order to comply with EU Directive 2012/19/EU on Waste Electrical and Electronic Equipment (WEEE): This product may contain material which could be hazardous to human health and the environment. DO NOT DISPOSE of this product as unsorted municipal waste. This product needs to be RECYCLED in accordance with local regulations, contact your local authorities for more information. This product may be returnable to your distributor for recycling - contact the distributor for details.

NOTE: This product contains Nickel Metal Hydride (NiMH) batteries which must be recycled. Refer to the Battery Disposal section on page 4 for details.

Monarch Instrument's Limited Warranty applies. See www.monarchinstrument.com for details.

Warranty Registration and Extended Warranty coverage available online at www.monarchinstrument.com.

TABLE OF CONTENTS

INTRODUCTION	1
FUNCTIONS AND OPERATION	1
SPSR Interface Module	1
Connections.....	2
Controls	2
LED Indication	3
Recharging the Batteries	3
SPSR-115/230 Series - SPSR-IM with ROS-P	3
ROS-P	3
Operating the SPSR as a triggering source	4
BATTERY DISPOSAL	4
COMPONENT SPECIFICATIONS	5
SPSR-IM Interface Module	5
ROS-P Remote Optical Sensor.....	6
SENSORS / OPTIONS AND ACCESSORIES	8

INTRODUCTION

The **SPSR-IM Self Powered Sensor Interface Module** is a self-contained, rechargeable battery powered device for developing a TTL compatible one pulse per revolution output for triggering external equipment such as vibration analyzers, spectrum analyzers, stroboscopes, data acquisition equipment, tachometers, balancers, waveform analyzers and magnetic tape recorders.

The **SPSR-115/230** is comprised of the **SPSR-IM Interface Module**, which provides power to a sensor and couples the sensor to a BNC output; an input sensor with a visible red LED light source (**ROS-P**); and a battery recharger.



SPSR-115/230
(SPSR-IM, ROS-P and Universal Recharger)

Optional sensors such as an optical laser sensor (**ROLS-P**-not shown), infrared sensor (**IRS-P**), or an amplified magnetic sensor (**MT-190P**) may also be combined with the **SPSR-IM Interface Module** when appropriate. (See separate instructions for these configurations.)



IRS-P
Infrared Sensor MT-190P
Magnetic Trigger Sensor

FUNCTIONS AND OPERATION

SPSR Interface Module

The **SPSR Interface Module (SPSR-IM)** provides power to the input sensor, receives and optionally inverts the return pulse signal, and provides a switch selectable positive going 0 to 5 Vdc or negative going 5 to 0 Vdc

pulse train trigger output on a BNC connector. Connections and operation are common to all SPSR models. Fully charged internal NiMH batteries will typically provide greater than 40 hours of continuous operation. In addition, the SPSR system can be operated continuously on external power by use of the recharger/power supply provided.

Connections

Connect the input sensor via the 1/8" [3.5 mm] phone plug to the mating connector on the **SPSR-IM**. This sensor may remain connected even when recharging the internal batteries of the **SPSR-IM**.

NOTE: Do not plug an input sensor into the SPSR with the Power switch in the "ON" position. Before plugging the sensor in, switch the power to "OFF" and unplug any external power supply.

Connect the output signal cable to the BNC connector on the opposite end of the **SPSR-IM** and to the external equipment to be triggered.

If operating from the recharger/power supply, connect the recharger to the connector marked "External DC" on the **SPSR-IM** and connect the wall unit to the appropriate power source.

Controls

The "Power" switch on the **SPSR-IM** controls both the operation and the charging of the system. The unit will only charge from external power in the power OFF position. In the power ON position, the unit will operate directly from external power any time that it is being supplied. Otherwise, it functions on internal battery power.

The "Output Selection" switch determines the polarity of the leading edge of the TTL compatible output signal. In the NON-INVERTING position, the output signal on the BNC connector will be a negative going 5 to 0 Vdc pulse derived directly from the conditioned sensor output. When the INVERTING position is switch selected, the BNC output signal will be a positive going 0 to 5 Vdc, TTL compatible.

LED Indication:

- Unit operational = solid green
- Unit charging = blinking red
- Charging done = solid red

NOTE: Short red blinks followed by long blink = Charge error, contact factory

Recharging the Batteries

To recharge the **SPSR-IM Interface Module** batteries:

1. Connect the recharger/power supply to the “External DC” input connector.
2. Connect the recharger/power supply into a working ac outlet.
3. Be sure the “Power” switch is in the OFF (CHARGE) position. The red “CHARGE” LED will indicate that the batteries are being charged. Allow up to 4 hours to fully charge.

SPSR-115/230 Series - SPSR-IM with ROS-P

The **SPSR-115/230** consists of the **SPSR-IM Interface Module** described above, an **ROS-P Remote Optical Sensor** with eight foot cable and mounting bracket, and an **SPSR-U (115/230 Vac)** external power connection. One foot of **T-5 Reflective Tape** is also supplied.

ROS-P

When connected to the **SPSR-IM** as described above, the **ROS-P** illuminates the target with a visible red light from a high intensity LED and detects the reflected pulses from the rotating reflective tape target with an internal photo-detector. The **ROS-P Remote Optical Sensor** is capable of detecting a reflected pulse from T-5 Reflective Tape targets at distances of up to 3 feet and angles up to 45 degrees from the target. The sensor is supplied with a set of two M16 jam nuts and a 90° angle slotted aluminum mounting bracket.

For most applications, a 1/2” square piece of T-5 Reflective Tape should be applied to a clean area on the rotating object. The sensor should be mounted and optically aligned to illuminate the reflective target once per revolution. **It is recommended that the optical sensor be placed at a slight angle (approximately 10-15 degrees) from perpendicular, so that the sensor will detect only the reflected pulses from the target.** The sensor should be at least 2 inches and no more than 3 feet from the target. The green LED On-Target Indicator on the **ROS-P** will blink at the input frequency or be continuously illuminated when properly aimed.

Operating the SPSR as a triggering source

Once the **ROS-P** input sensor is properly mounted and aligned, further connections and operation should proceed in accordance with the functions and descriptions under the **SPSR Interface Module** sections entitled ‘**Connections**’ and ‘**Controls**’.

The pulse signal on the connector marked “Output” provides a sharp leading edge for reliable and repeatable triggering of the connected device. This output is capable of driving a hundred feet of coax cable. Be sure to select the direction (0 to 5 Vdc or 5 to 0 Vdc) of this signal to provide the required polarity of the leading edge to properly trigger the connected equipment.

BATTERY DISPOSAL

Prior to disposing of the **SPSR-IM**, the user must remove the Nickel Metal Hydride batteries. To do this, remove the four (4) rubber feet on the bottom of the unit. This will expose four (4) screws that must be removed to dismantle the bottom case piece, exposing the batteries. Remove the batteries and place tape over the battery terminals to prevent them from shorting. The batteries should be sent to a recycling center or returned to the factory. The rest of the parts may now be disposed of.

NOTE: This product contains Nickel Metal Hydride (NiMH) batteries. Replace only with the same type of battery – Rechargeable NiMH.

COMPONENT SPECIFICATIONS

SPSR-IM Interface Module

Internal Batteries: Nickel Metal Hydride (NiMH) Battery Pack, 4.8 Vdc

Operating Interval: >40 hours typical with ROS-P (~40mA load)

Charge Time: up to 4 hours

Output: TTL compatible pulse, INVERTED or NON-INVERTED – switch selectable. With an ROS (negative pulse) input, the output will be a positive pulse when set to inverted or negative pulse when set to non-inverted. Optionally, the output can be open collector (external pull up is required).

Bandwidth: 0 to 100 kHz

Battery Current Draw: 12mA with 10 kΩ load (operational)

7.5V Input Current Draw: 14mA with 10 kΩ load (operational)

Power Supply: SPSR-U (operational/charge)

LED Indicator: Status indication, see LED Indication section

Output Connector: BNC Connector (female)

Operating Temp: 32° F to 122° F [0° C to 50° C]

Weight: 8.3 oz. [235 grams]

Dimensions: 5.0" x 2.5" x 1" [127 mm x 64 mm x 25 mm]

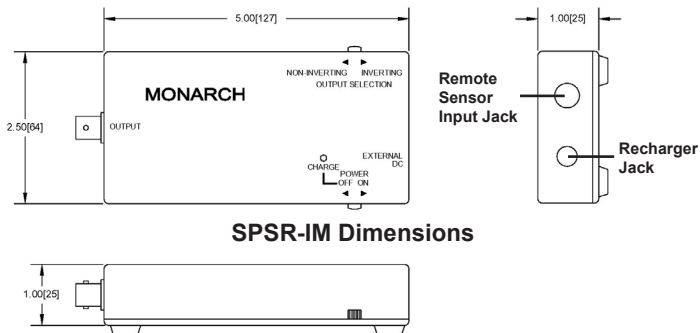

SPSR-IM Dimensions

ROS-P Remote Optical Sensor

Operating Envelope: Up to 3 feet [0.9 m] and 45° from reflective target

Speed Range: 1 to 250,000 RPM

Illumination Source: Visible red LED, 5 Vdc @ 30 mA

Operating Temp: 14° F to 158° F [-10° C to 70° C]

Output Signal: 5 to 0 Vdc TTL compatible pulse

On-Target Indicator: Green LED on end cap

Material: 303 Stainless steel

Lens: Acrylic plastic

Cable Length: 8 feet [2.5 m] Standard

Dimensions: Threaded Tube - 2.90" L x 0.625" diameter [M16 x 1.5 x 74 mm] supplied with two M16 jam nuts and mounting bracket

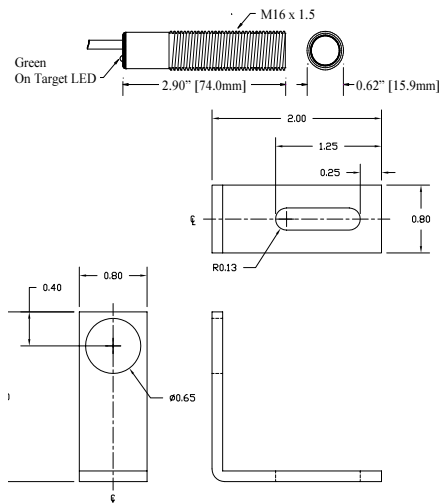

ROS-P and mounting bracket Dimensions

Compliance: Both the SPSR-IM and ROS-P units are CE compliant.
Low Voltage Directive (LVD) 2014/35/EU
Electromagnetic Compatibility Directive (EMC) 2014/30/EU
Restriction of Hazardous Substances (RoHS) Directive
2011/65/EU

SENSORS / OPTIONS AND ACCESSORIES

ROS-P	Remote Optical Sensor with 8 foot [2.5 m] cable and mounting bracket
ROS-P-25	Remote Optical Sensor with 25 foot [7.6 m] cable and mounting bracket
ROLS-P	Remote Optical Laser Sensor with 8 foot [2.5 m] cable and mounting bracket
IRS-P	Infrared Sensor with 8 foot [2.5 m] cable for use without reflective target at 0.5 inch [12.7 mm] gap (5 to 500,000 RPM)
MT-190P	Magnetic Trigger Sensor/Amplifier with 8 foot [2.5 m] cable - 0.250" [6.4 mm] operating gap from target, 2" (L) x 5/8" [50.8 x 15.9 mm]
EC-25P	25 foot [7.6 m] Extension Cable for remote sensors with male 1/8" [3.5 mm] phone plug to female 1/8" [3.5 mm] connector
T-5	Reflective Tape, 5 foot [1.5 m] roll, 1/2 inch [13 mm] wide
T-5WP	Waterproof Reflective Tape (honeycomb pattern), 5 foot [1.5 m] roll, 1 inch [25 mm] wide
BP-R	Replacement NiMH Battery Pack (for SPSR-IM ONLY)
SPSR-U	Universal Recharger with plugs, 115/230 Vac - 50/60 Hz

Check out some of our other product lines...



**Handheld
Tachometers**



**Panel
Tachometers**



**Portable
Stroboscopes**



**Machine Vision
Stroboscopes**



Speed Sensors



**Temperature/
Humidity Sensors**



Vibration Meters

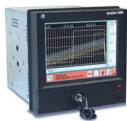

Paperless Recorders



Track-It™ Data Loggers

Printed in the U.S.A.
Copyright 2007-2019, Monarch Instrument, all rights reserved

1071-4847-118